



## 6000 Series Introduction



## Contents list.

1.0	Why develop a new series of wiper control systems? .....	3
2.0	Systems benefits .....	4
3.0	System components.....	5
3.1	Series 6000 Control System Description.....	6
4.0	Keypad introduction.....	8
5.0	Slave keypads.....	9
6.0	Keypad Individual Part Number (IPN). .....	10
7.0	Remote switches.....	11
8.0	Keypad Configurations.....	12
9.1	Typical Bridge Layout – Single Keypad.....	15
9.2	Typical Bridge Layout – Multiple Keypads (Slaves).....	16
9.3	Typical Bridge Layout – Multiple Keypads (Masters).....	17
9.4	Installation Of Shielded Twisted Pair Cable .....	18
10.0	Keypad Installation and dimensions.....	21
11.0	Modules.....	23
11.1	6100 115/230 Vac 1 phase module.....	23
11.2	6100 Module variation.....	24
11.3	6300 115/230 Vac 3 phase module.....	25
11.4	6300 Module variation.....	25
11.5	6100/6300 Module dimensions.....	25
11.5	6100/6300 Module dimensions.....	26
11.6	6100 Module Installation .....	27
11.7	6100 Module wiring. ....	28
11.8	6300 Module Installation. ....	29
11.9	6300 Module wiring. ....	30
11.10	6100 and 6300 Module Individual Part Number (IPN).....	31
11.11	6200 DC Module .....	31
11.12	6200 Module Dimensions.....	32
11.13	6200 Module Installation. ....	33
11.14	6200 Module Individual Part Number (IPN).....	33
11.15	6200 Module wiring. ....	34
12.0	External PSU.....	35

## **1.0 Why develop a new series of wiper control systems?**

Existing systems could not longer fulfil all the requirements.

The market screamed out for smaller systems with more options, easy to operate for less cost.

Ship bridges are packed with systems, all of them important for a safe navigation. There is hardly any room left for big panels and cabinets.

The wipers are becoming more and more a critical safety item. The number of wipers per vessel keeps growing. This means the conventional wiper control system had even to grow more in size or have to be replaced by a more intelligent type of system.

Therefore we decided take our 3000 concept and develop a new sophisticated range - the 6000 series.

## **2.0 Systems benefits.**

The 6000 series fulfils all requirements needed to operate window cleaning systems using a very small keypad and a few modules.

The system can control not just the wipers but also interface with wash systems which mix detergent, glycol and water.

Wash/purge, intermittent timings can easily be programmed at the keypad

It reduces cost on cable and installation time, and the remaining cable is lighter duty.

There are no separate modules needed for case heater, arm heater, window heater, wash and purge, these functions are integrated into the motor module.

One power supply cable to each module instead of separate power supplies for each option.

The system has a built in current monitoring system. It monitors each wiper and if the current goes up the system automatically switches the wiper off. It avoids extra damage when there are installation issues.

The system offers a great flexibility. Large bridges can be divided in zones; each zone can be divided in groups

Different electrical supplies and voltages can be controlled in the same system. This offers the option to use less expensive wipers for less safety critical windows without having the need for a separate control system.

Additional wipers or equipment can be added at a later date without complicated design changes.

### **3.0 System components.**

The systems exist of five hardware components.

- i. Keypad
- ii. Module for 1 Phase power supply systems.
- iii. Module for 12 or 24 Vdc supply systems.
- iv. Module for 3 Phase systems.
- v. Additional PCB for extra outputs.

Designing a system which complies with all the wishes and can be fulfilled with a small number of components is a big benefit for us, the manufacturers and the end user.

Fewer components help to achieve a better stock control.

It is easier to maintain the system.

The variety of options is the software.

The software is written in a standard industrial language. This standard is used World Wide, the benefit is that we not have to rely on one software developer or one software company only.

The software is stored in the keypad and not divided over the different hardware components (modules).

The big benefit is when a customer wants to update or expand his system with extra wipers he needs only to update one component, the keypad and not change the software in the existing modules as well.

### 3.1 Series 6000 Control System Description

Series 6000 Control System uses a 3-wire communications bus to connect a number of control modules back to a central keypad. The bus signals are BUS+, BUS-, and 0V. The system also requires a stabilised 24Vdc power source with a minimum 150mV pk-pk ripple voltage,  $\pm 1.0\%$  Voltage tolerance,  $\pm 0.5\%$  line regulation and  $\pm 1.0\%$  load regulation. This adds a 24V line to make a 4-wire bus.

It is recommended that the Wynn supplied PSU is used to provide a regulated, stabilised and independent power source. If an existing ships 24V supply is to be used then it must be galvanically isolated with a DC to DC converter, this is to reduce the effects of noise on the 0V line from the ships supply interfering with the bus communications. Each independent control system should have its own power supply.

Wiring is recommended to consist of a twisted pair for the communication lines (+, -) and a twisted pair for the power lines (24V, 0V). The cable must comply with the DeviceNet specification and the communication pair have a characteristic impedance of 120 Ohms. The cable size is dependant on the total length of the bus:-

Total Bus Length	Min Cable Size	
	Power	Data
Up to 100m	1.5 mm <sup>2</sup> (15 AWG)	0.96mm <sup>2</sup> (18 AWG)
Above 101m	2.5 mm <sup>2</sup> (13 AWG)	0.96mm <sup>2</sup> (18 AWG)

A terminating resistor module must be connected across the communication lines at the first keypad and the last module.

Control modules have a unique address, preset at our factory or can be reset by the customer, so wipers can be selectively controlled from the keypad. Wiper modules are extremely flexible in the combination of functions they may control. They may be factory configured to provide most combinations of wiper, wiper heater, wash/purge system and window heat control.

Power for the wiper, heater or wash system is taken directly to the Series 6000 control module adjacent to the heater or wash system, with a keypad flush mounted into the Bridge Console. DC Wiper Modules may be pre-wired to the wiper's motor with address settings preset according to the agreed control grouping.

AC Modules may be configured with a single AC input providing power to Motor, Heater, Wash and Air Purge; or may be provided with mixed supplies for 230V AC Motors and 24V AC or DC Heaters.

Onboard current monitoring circuitry in the AC modules will isolate and shut down any input taking too much or too little current, whilst leaving other circuitry still working.

The Bridge Layout Drawing and System Wiring Diagram should be used to identify correct location and wiring of all wipers and modules. Each module/wiper combination is unique to a specific group, with the identification of a specific wiper shown on the Bridge Layout Drawing. Rotating the small rotary switch accessible with a screwdriver through the front panel may change the module group address.

Three Control Module Types are available: The 6100 for Single Phase motors, 6300 for Three Phase motors and the 6200 for 12 or 24V DC motors. The 6500 keypad is available in many configurations to control these modules (See 6500 keypad variation drawing).

Most modules are available with two additional outputs for wash, purge, case/arm heat and window heat. The module can only be configured for a maximum of one of each type of output.

The standard 6100 module has standard two additional outputs.

The extended 6100 module has four additional outputs.

The standard 6200 modules has only one additional output option. The output can be set by DIP switch for wash, purge, case/arm heat or window heat.

The standard 6300 module has no additional outputs.

The extended 6300 module has two additional outputs.

### **Technical specifications**

Input supply bus:	24Vdc +/- 2 V
Current consumption Keypad:	55mA
Current consumption Standard 6100/6300 Module:	65mA
Current consumption 6200 Module:	20mA
Current consumption Extended 6100/6300 Module:	110mA

## 4.0 Keypad introduction.

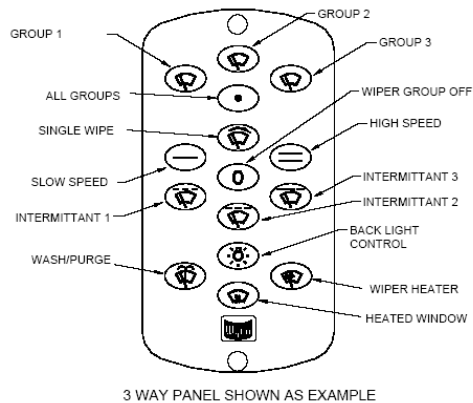

The system is controlled from a conveniently positioned control keypad available as single speed (1Ph SLW motors) or two speed (3Ph SLW motors and panto/pend motors) or a combination of the different wipers.

The standard keypad consists of;

- Master Group Control,
- Master off.
- Normal and high speed switches.
- 1 to 7 Groups
- All Groups Single Wipe, 3 Intermittent Wipes, Wash/wipe,
- Case Heat and Window heat
- Back light dimmer control to zero.

The buttons have international recognized symbols for identification of the functionality. Benefit, no need for the supply of keypads in different languages.

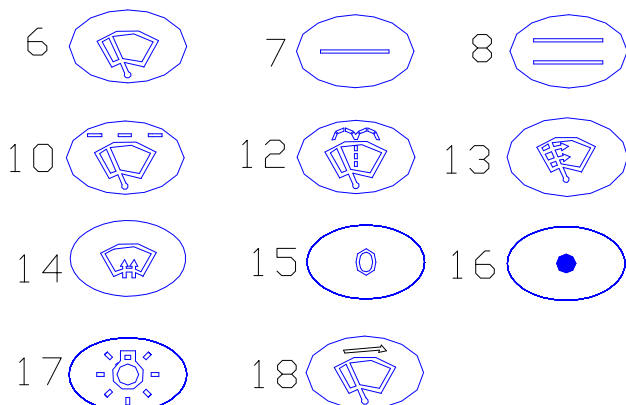

ENLARGED VIEW OF BUTTONS

- 6 - Wiper or group button
- 7 - Normal speed
- 8 - High speed
- 10 - Intermittent
- 12 - Wash
- 13 - Arm or case heater
- 14 - Window heater
- 15 - Off
- 16 - Master on
- 17 - Dimmer
- 18 - Single wipe.

## 5.0 Slave keypads.

It is possible to add slave keypads up to a maximum of 6 per system. The slave keypads will always have the same functionality as the master keypad. To take over command from one keypad to the other is simply to push any button on the keypad wishing to take command (flashing lights).

When wipers are already in operation during take over command the last selected function will remain valid. For instance when the wipers are in normal speed mode and command is transferred to another controller the wipers will continue to work in normal speed mode.

**The exception is when the wash cycle has started; the complete cycle will be finished first before the transfer happens.**

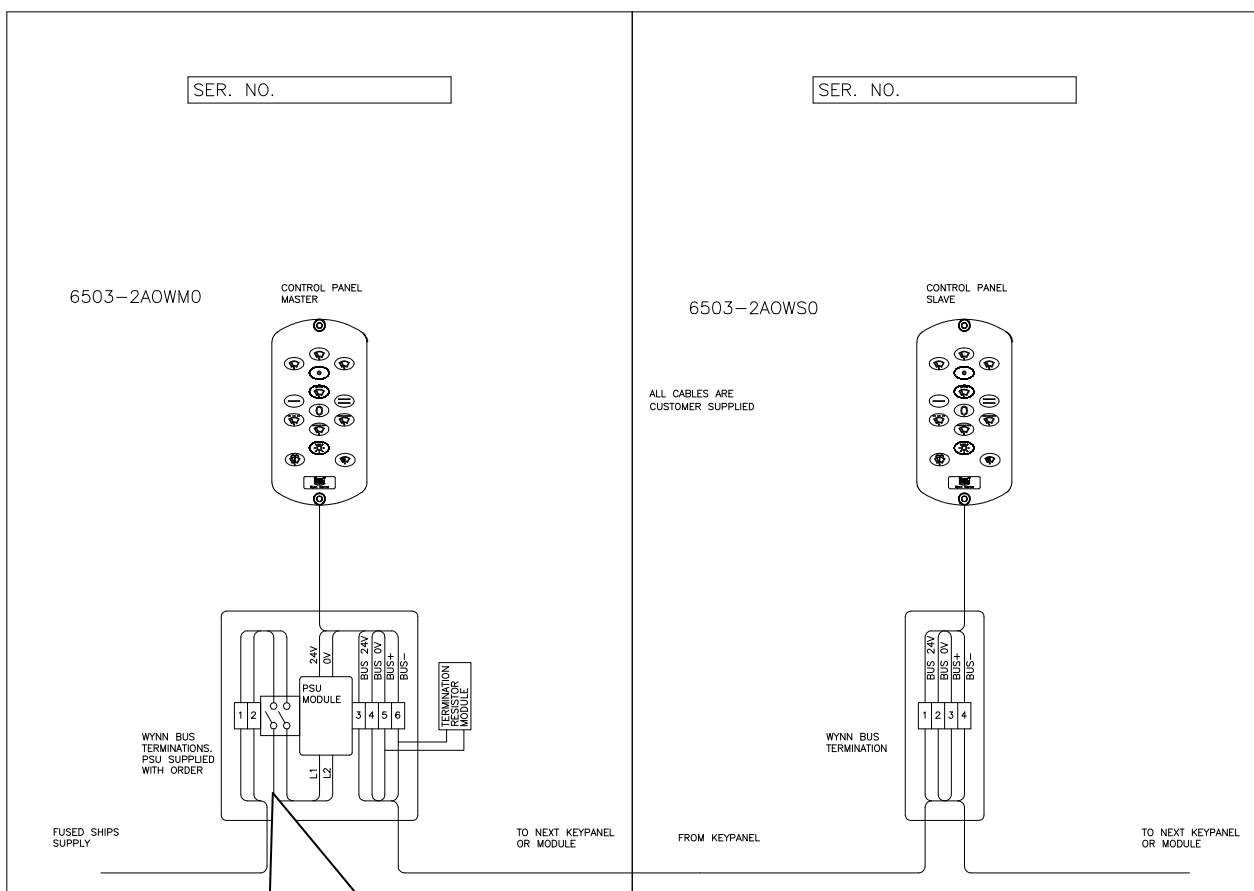

Example of a wiring schematic with a terminal box and integrated 3000-006 PSU. Optional available.

## 6.0 Keypad Individual Part Number (IPN).

Wynn has adopted the IPN system from Hepworth who has used this for many years. People, when they were confronted with the IPN's the first time, found it very complicated. It is not complicated at all the IPN is the best invention since sliced bread.

The following explanation of the IPN for a keypad demonstrates the benefits of using an IPN.

- 6     *Member of the 6000 series*
- 5     *Keypad*
- \*\*    *Number of wipers or groups with a maximum of 7*
- 
- \*     *Speed, 1 = single speed (1Phase supply), 2 = two speed (3 Phase supply, 12/24Vdc and 70/100Nm 1 Phase)*
- \*     *Arm/case heater, 0 = no heater, A = with heater*
- \*     *Window, 0 = no heater, W = with heater*
- \*     *Wash a 0 = no wash, a W = with wash*
- \*     *Master or slave, M = master, Slave = S (1)*
- \*     *Remote switch, 0 = no switch, R = remote switch (2)*

1.     It is possible to have 6 slaves in a system, the first slave keypad will have an **S** the second will have a **2** etc.
2.     There are different remote switch options available.
  - R** = push the button and all wipers will start, push again and all the wipers stop.
  - 1** = push the button and hold it all the wipers will work as long as the button is hold.
  - 2** = push the button all wipers will make one wipe.

The IPN gives the info as to which buttons and software is needed. The IPN is also the part number. Re-ordering using the IPN tells us what is needed. No longer digging in old works orders to find out what was supplied.

The IPN is on a label on the back of the keypad but also in the drawings available in the issued manuals.

## 7.0 Remote switches.

Remote switches are a simple and cost effective solution to offer the flexibility of operating the wipers from every convenient place.

The remote switch is connected to the keypad with an extra cable; standard keypads cannot be extended with a remote switch at a later stage. The keypad has additional software and the cable is soldered direct on the keypad PCB.

There are different remote switch options available, push the button and all wipers will start push again and all the wipers stop, push the button and hold it all the wipers will work as long as the button is hold, push the button all wipers will make one wipe

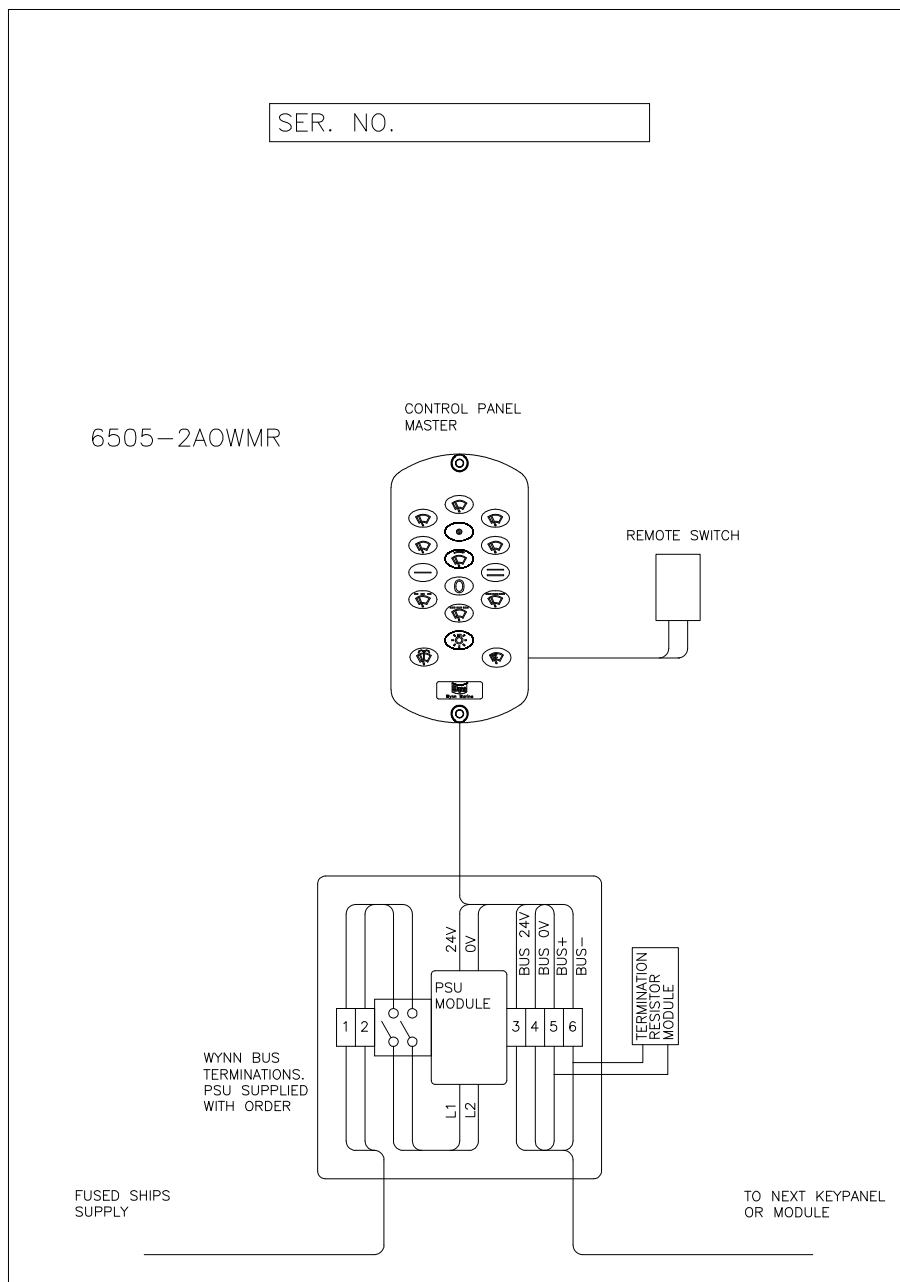

## 8.0 Keypad Configurations

The Keypad may be supplied in a number of formats; from one-way/group to seven-way/group, and single-speed or two-speed. The following diagrams show the layouts for all formats. The Group buttons are labelled for illustrative purposes only.

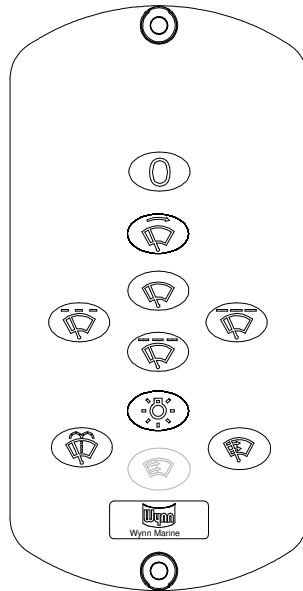

1 way, single speed

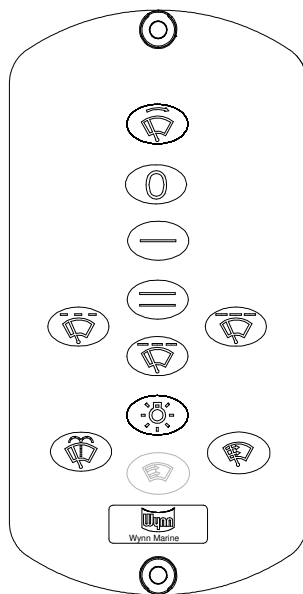

1 way, two speed

### Single Group Format

Note: Greyed keys may or may not be present, depending on how the Keypad is specified.

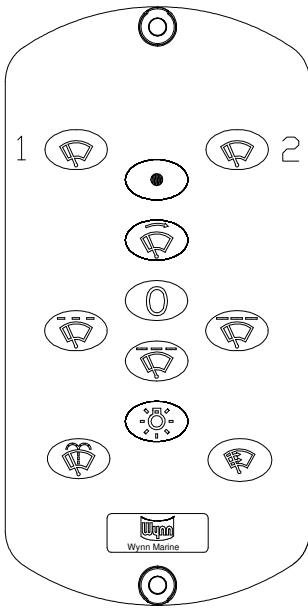

2 way, single speed

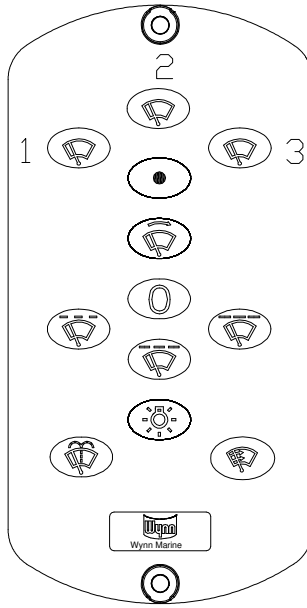

3 way, single speed

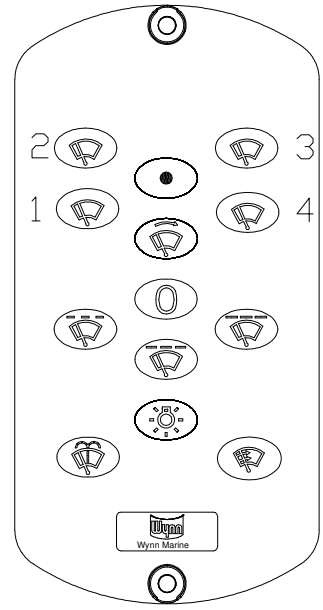

4 way, single speed

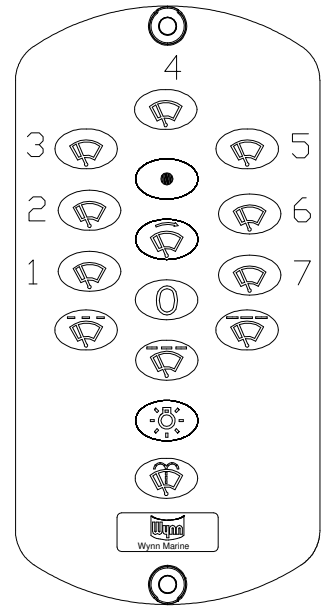
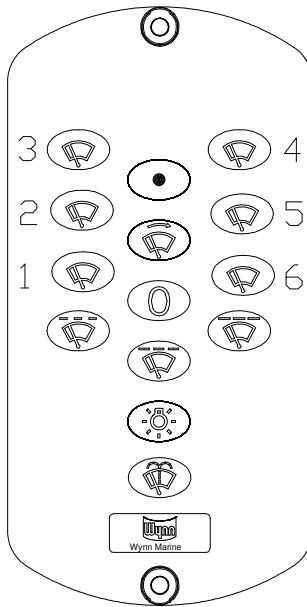
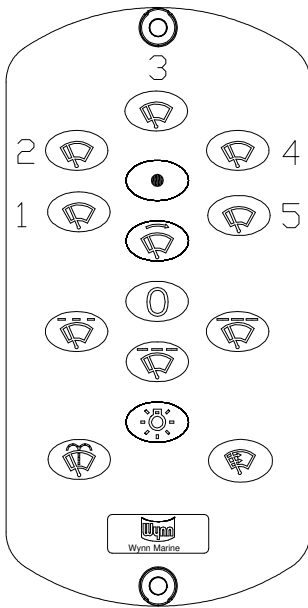

### Multi-Group, single-speed format

Note: Greyed keys may or may not be present, depending on how the Keypad is specified.

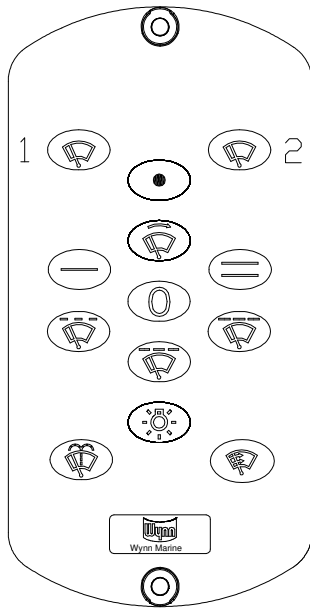

2 way, two speed

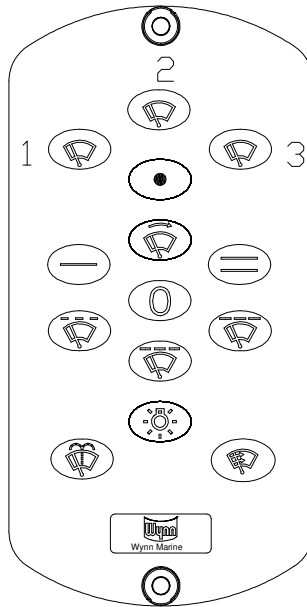

3 way, two speed

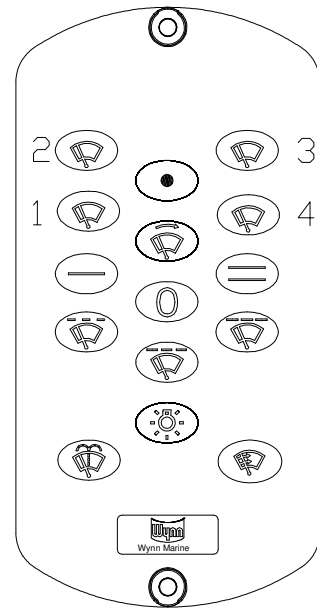

4 way, two speed

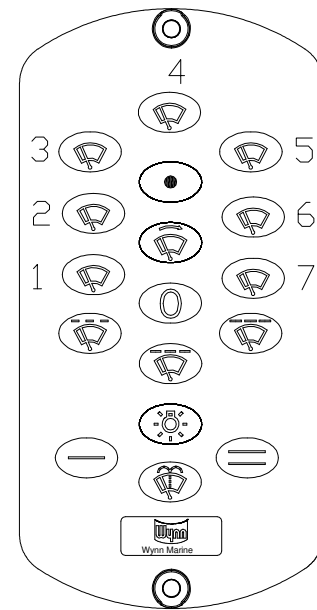
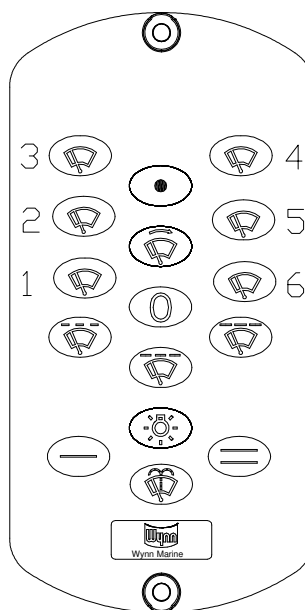
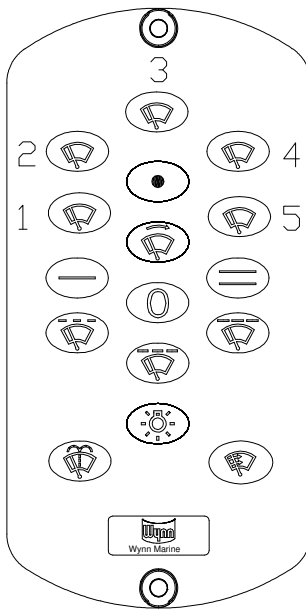

### Multi-Group, two-speed format

Note: Greyed keys may or may not be present, depending on how the Keypad is specified.

# 9.1 Typical Bridge Layout – Single Keypad

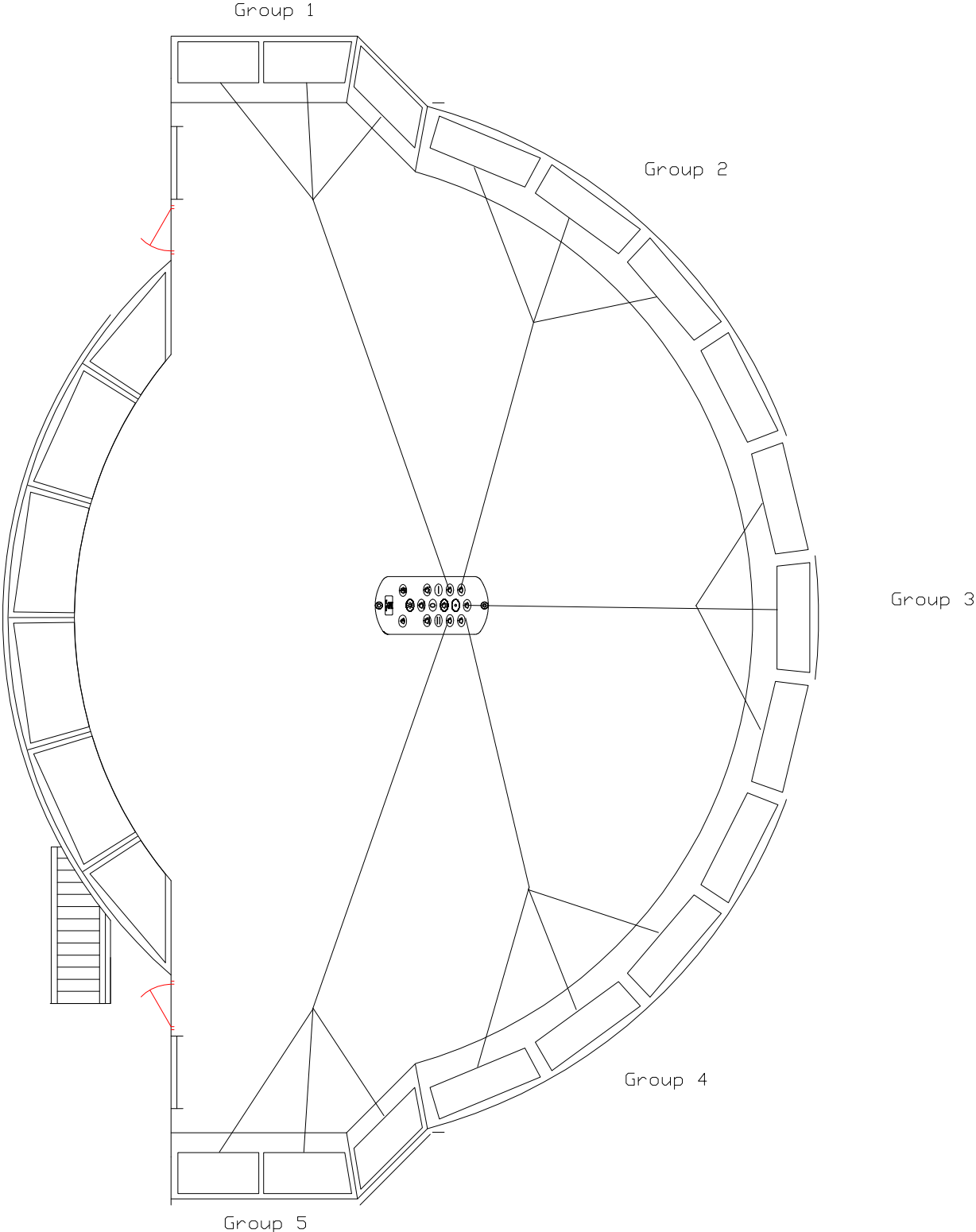

# 9.2 Typical Bridge Layout – Multiple Keypads (Slaves)

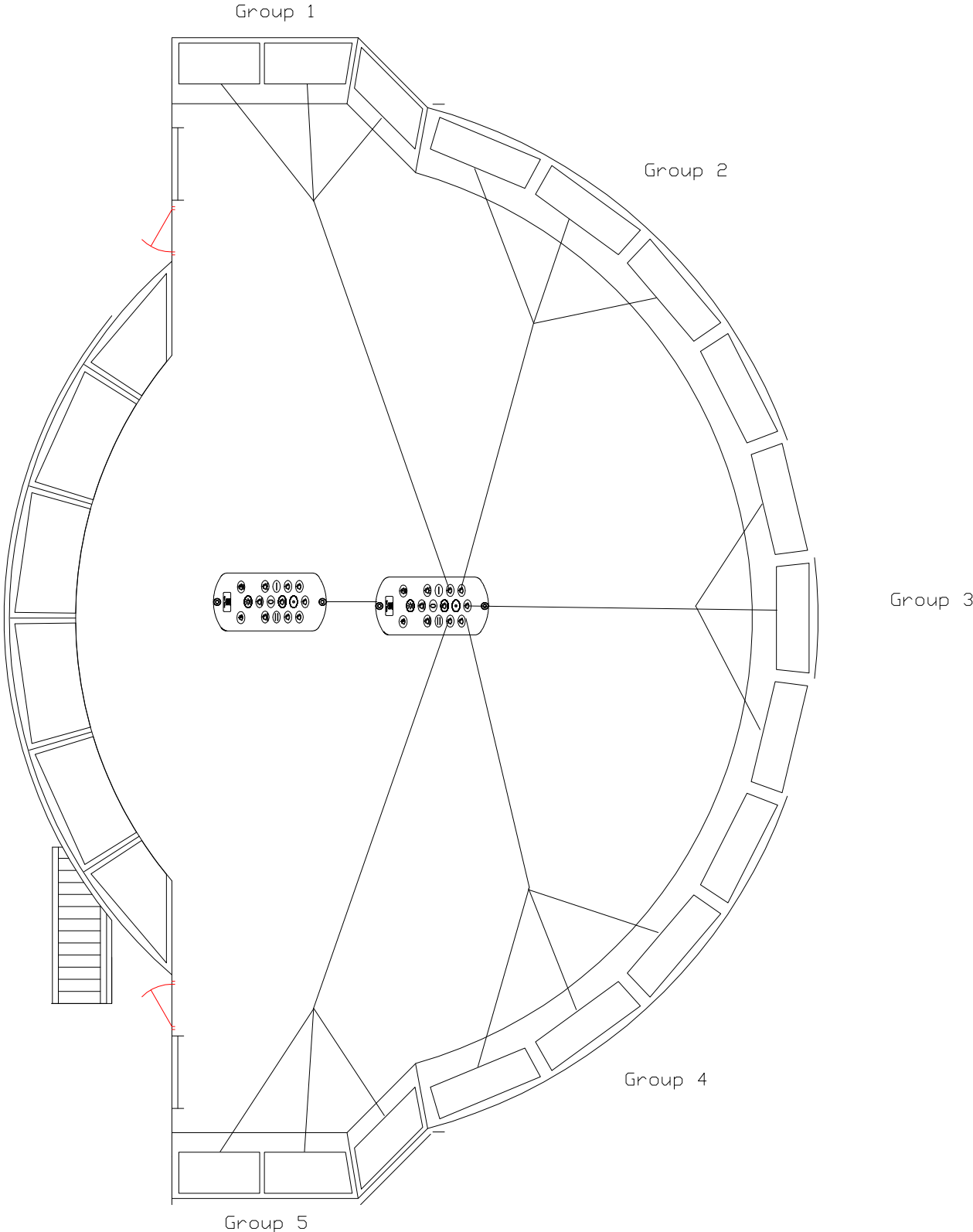

# 9.3 Typical Bridge Layout – Multiple Keypads (Masters)

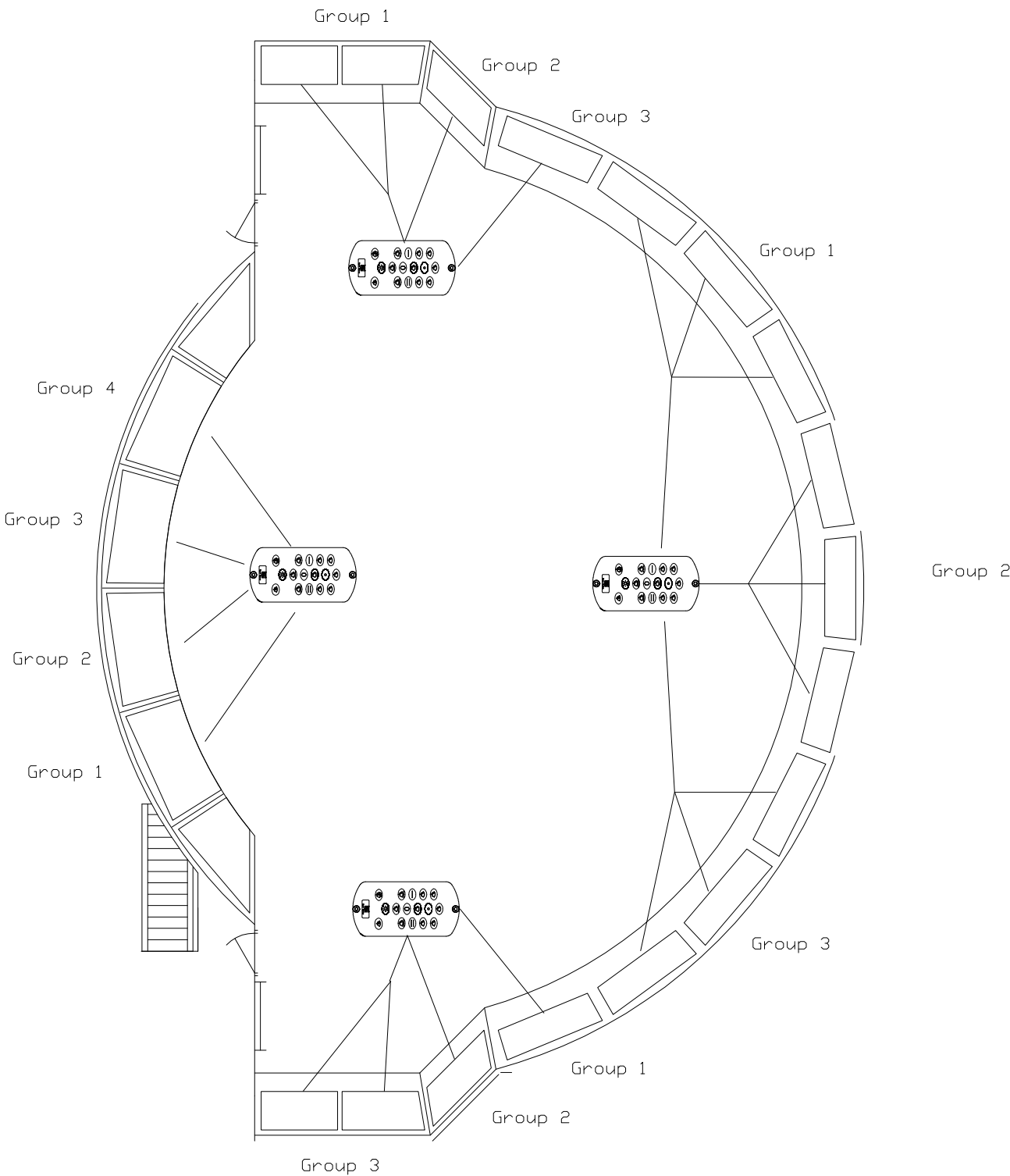

## 9.4 Installation Of Shielded Twisted Pair Cable

### Belden DeviceBus ® for ODVA DeviceNet



- 300V Class 2 Thin
- 22 and 24 AWG Stranded Tinned Copper
- 100% individually foil shielded + overall 65% TC Braid
- Drain Wire
- PVC Insulation (Power)
- FPE Insulation (data)
- Lt Gray sunlight / oil resistant PVC jacket
- Thin 75°C
- **Conductor (stranding) Diameter Nom. DCR** - (2) 22 AWG TC (154 x 44) 17.5  $\Omega$ /M', 57.4  $\Omega$ /km
- **Conductor (stranding) Diameter Nom. DCR** - (2) 24 AWG TC (105 x 44) 28.0  $\Omega$ /M', 91.9  $\Omega$ /km, Nom. Characteristic Impedance 120  $\Omega$ , Nom. Capacitance Conductor to Conductor 12 pF/ft
- **Shielding materials Nom. DCR** - 100% individual foil + overall 65% TC braid 3.2  $\Omega$ /M', 10.5  $\Omega$ /km
- **Nominal OD** - 0.28", 7.11mm

This guide is based on the use of Belden 3084A cable (or similar, see specification above).

The cable is made up of a 22AWG power pair (red/black) and a 24AWG data pair (blue/white), each pair is individually foil screened with a drain wire, and an overall shielding braid.

For installation in a Wynn 6000 Series Network Control System, the screen needs to be terminated at one end only of each length of cable. Please note that connection of the screen at both ends of the cable may cause interference to the data bus on the cable and disrupt the operation of the wipers.

One end of the cable should be prepared as follows:-

1. Strip the outer insulation back 50mm
2. Carefully peel back the braid and twist to form a conductor.
3. Remove the foil insulation leaving 5mm showing.
4. Untwist each pair and strip back insulation on each conductor 5mm and twist strands together.
5. Twist the braid conductor and drain wire together and terminate with an eyelet. The cable should now look something like this:

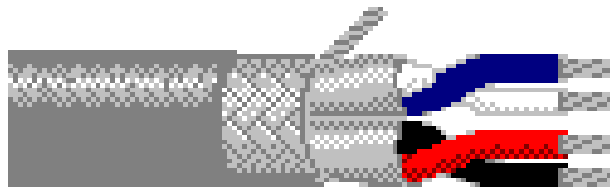

6. Secure the eyelet to the ships metal work using a suitable self-tapping screw, lock wash and plain washer, applying silicon grease to the surface prior to fitting. This is the preferred method.

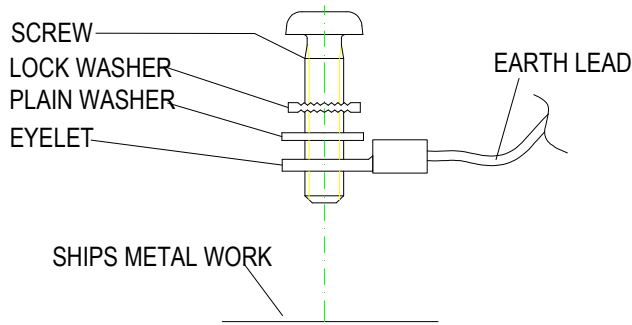

*If the ships hull is non metallic or if there is no suitable earth bonding point is available then an alternative is to connect the braid to an appropriate point on the earth system, such as the control module earth located at the opposite end on the module.*

*The control module earths can only accommodate two connections, so if more than two earths are required to be connected to the module they must be joined together with a suitable connector and then a fly lead connected to the control module.*

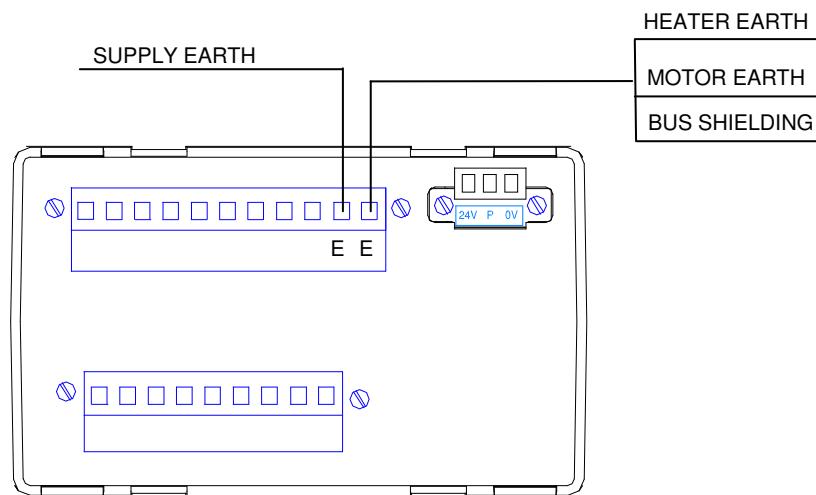

7. Connect the conductors to the keypad/module 4 way bus connector as follows:

Bus Connection	Colour
24V Power	Red
0V Power	Black
Bus -	White
Bus +	Blue

The other end of the cable should be prepared as follows:-

1. Strip the outer insulation back 50mm
2. Carefully peel back the braid and cut off.
3. Remove the foil insulation leaving 5mm showing and cut off the drain wire.
4. Wrap insulating tape around the cut off braid and foil insulation.

5. Untwist each pair and strip back insulation on each conductor 5mm and twist strands together.
6. Connect the conductors to the keypad/module 4 way bus connector as follows:

Bus Connection	Colour
24V Power	Red
0V Power	Black
Bus -	White
Bus +	Blue

## 10.0 Keypad Installation and dimensions.

### Installation

Installation procedures must be carried out with care, to ensure correct and safe operation. If you are in any doubt, consult qualified and competent engineering personnel, or consult Wynn Marine technical support (contact details on front and rear cover of this document). The installation procedure consists of mounting to a suitable panel cut-out, and wiring to the four-way connector on the rear of the enclosure. The Keypad can be mounted in any plane; ensuring access can be gained to the rear connector. There are no adjustable or user-serviceable parts within the keypad.

### Keypad Dimensions

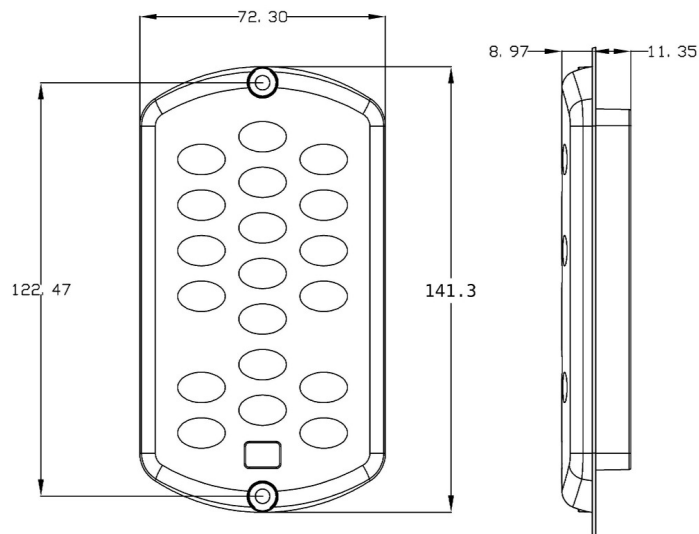

**6500 KEYPAD DIMENSIONS**

The overall keypad dimensions are shown in the diagram above (not to scale).

### Panel Cut-Out Requirements

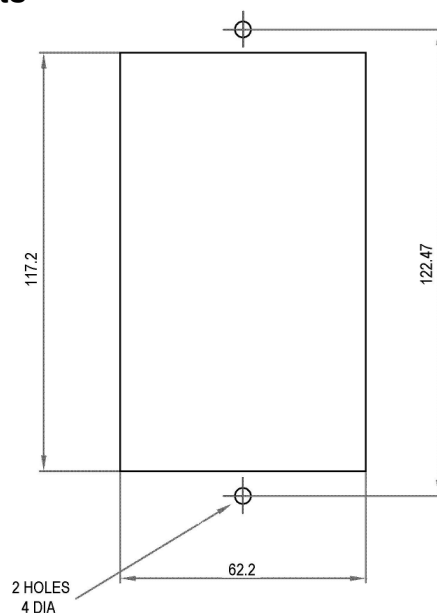

**6500 KEYPAD PANEL CUT OUT DIMENSIONS**

The 6500 keypad must be panel mounted. Provide a cut out in the console for the keypad according to the dimensions given above (not to scale). The key pad is secured to the panel by M4 fixings (not supplied):

- M4 x 12 pan-head screw (2 off, inserted through front of keypad)
- M4 plain washer (2 off)
- M4 shake-proof washer (2 off)
- M4 nut (2 off, to rear of mounting panel)

## Connection Details

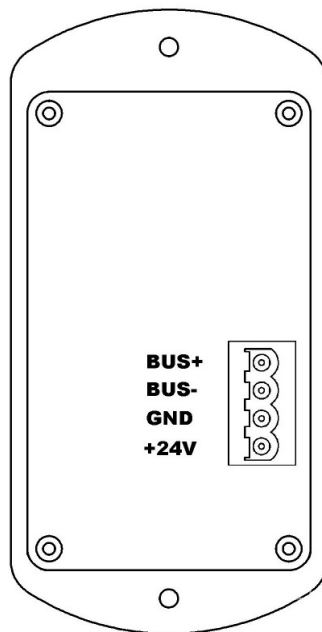

## 6500 KEYPAD: WIPERNET CONNECTION DETAILS

The 4-way connector mounted on the rear of the keypad enclosure accepts a Phoenix Contact style plug-in screw terminal. The diagram above details the electrical connections. Mate the connectors only when you are sure the wiring is correct. Connect the plug firmly. Make all connections with the power off. Connect a terminating resistor module across the BUS+ and BUS- connections (first keypad only).

**WARNING!** Incorrect connections may damage the internal circuitry within the 6500 keypad. Ensure wiring is correct before applying power to the keypad.

For Multiple Keypad systems, the WiperNet wiring is recommended to start from the Master Keypad then onto the Slave Keypad continuing to the last Slave Keypad (up to Slave 6 Keypad), then onto the first Motor/Auxiliary module, finishing with the remaining modules within the system.

Wiring is recommended to consist of a twisted pair for the communication lines (+, -) and a twisted pair for the power lines (24V, 0V) of a minimum 0.5mm cross-sectional area (not supplied). The cable must comply with the DeviceNet specification and the communication pair have a characteristic impedance of 120 Ohms. (Not supplied)

WiperNet system wiring **MUST NOT** be terminated as a loop.

## 11.0 Modules.

There are three types of modules each type will be explained separately in this manual although they can be used all together in one system.

The modules are divided by power supply; 6100 115/230Vac 1 phase, 6200 12/24 Vdc and the 6300 115/230 Vac 3 Phase.

### 11.1 6100 115/230 Vac 1 phase module.

The module is available in several variations. The variations are the different outputs. A standard module has the option to have two additional outputs. The outputs can be configured for wash (solenoid or pump), purge (solenoid), arm/case heater and window heater.

The module is also available with a second PCB with two extra outputs.

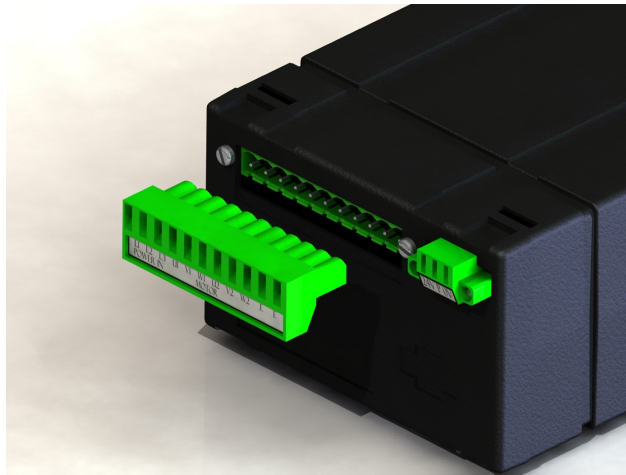

**Standard module.**

When 70/100 Nm 2 speed self park 115/230 Vac 1Phase pantograph systems is used in combination with the 6000 series then the motor module used is the 6300 3 Phase module.

One Phase is the power supply input the other two Phases are used for the speed outputs.

## 11.2 6100 Module variation.

6100 CONTROLLER	DESCRIPTION
ASSY	
1 61\$00000E**	1 PHASE WIPER ONLY
2 61\$10000E**	1 PHASE WIPE & WASH
3 61\$11000E**	1 PHASE WIPE, WASH & PURGE
4 61\$00010E**	1 PHASE WIPE & CASE HEAT
5 61\$10010E**	1 PHASE WIPE, CASE HEAT & WASH
6 61\$01010E**	1 PHASE WIPE, CASE HEAT & PURGE
7	
8	
9 61\$11011E**	1 PHASE WIPE, WASH, PURGE, CASE HEAT & SCREEN HEAT
10	
11	
12	
13 610011010E**	WASH, PURGE & HEAT ONLY
14 610011011E**	WASH, PURGE, CASE HEAT & SCREEN HEAT ONLY

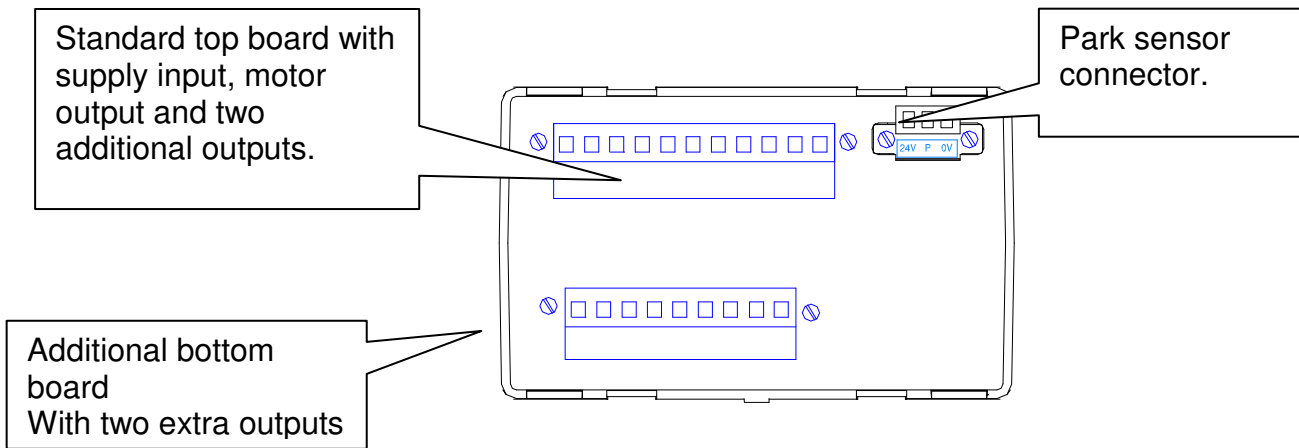

### 11.3 6300 115/230 Vac 3 phase module.

The module is available in several variations. The variations are the different outputs. A standard module has no additional outputs. The module requires a second PCB for two extra outputs. The outputs can be configured for wash (solenoid or pump), purge (solenoid), arm/case heater and window heater.

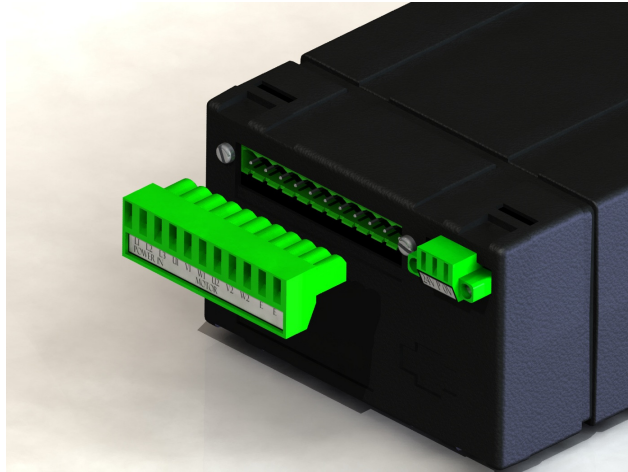

Standard module.

### 11.4 6300 Module variation.

6300 CONTROLLER	DESCRIPTION
ASSY	
1 63\$\$\$00000E**	3 PHASE WIPER ONLY
2 63\$\$\$00010E**	3 PHASE WIPE & CASE HEAT
3 63\$\$\$10010E**	3 PHASE WIPE, WASH & CASE HEAT
4 63\$\$\$11000E**	3 PHASE WIPE, WASH & PURGE
5 63\$\$\$10000E**	3 PHASE WIPE & WASH

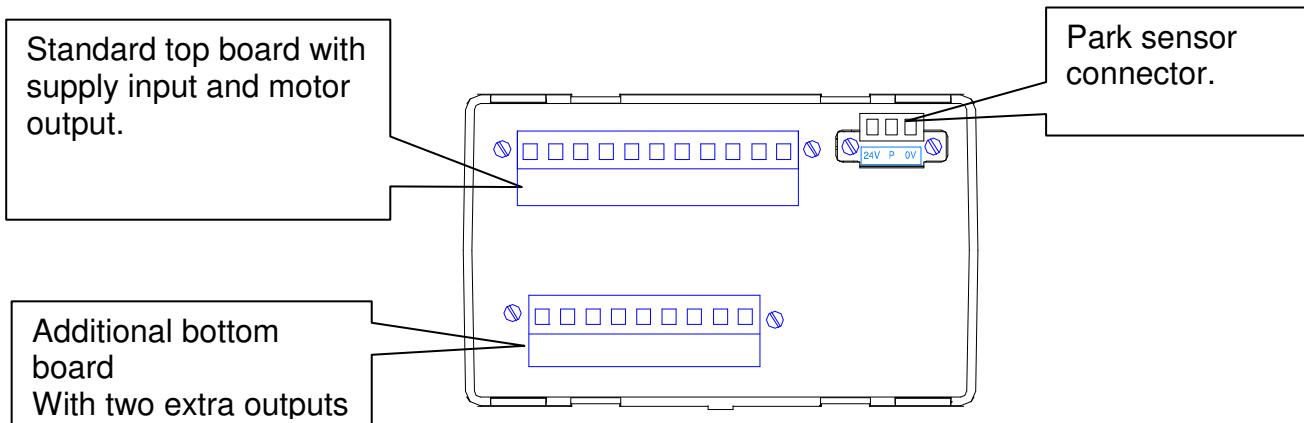

## 11.5 6100/6300 Module dimensions.

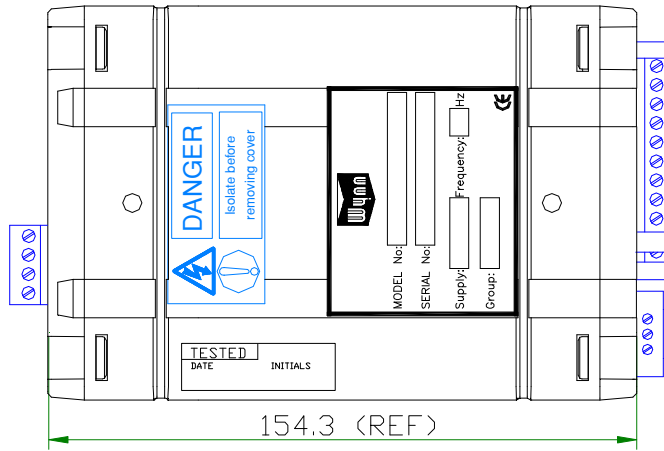

4 wire bus connection from keypad to next module or from previous module to next module.

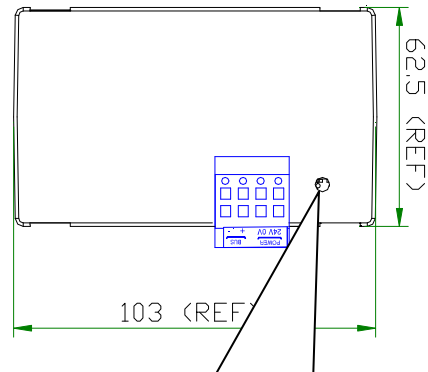
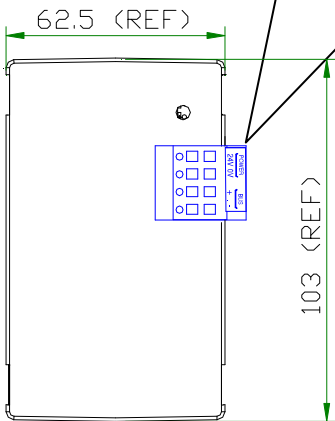

With a small screwdriver it is possible to change group settings. Turning it clockwise to go up a step and anti-clockwise to go down a step. Each step is a group. There are fifteen positions, only the first Seven are in use.

## 11.6 6100 Module Installation

Wiper modules must be mounted within the same group, the group number being marked on the control module labelling and illustrated on Bridge Layout drawings.

For 6100 modules, Motor power and two additional outputs may be switched via the 11-way connector. This can be any combination of case heat, wash, purge and window heat.

Recommended is to use one output for the case heater, this can save cost in cable.

The 9-way connector will be fitted for additional options (i.e. if Heat, Wash and Air Purge are needed). For split power sources (i.e. 230VAC Motor with 24V AC or DC Heaters), power to the Heater is derived from the 9-way connector).

1. Choose a location for the Motor Control module so that it is within range of the motor cable and park switch cable. Mount the modules with the fixing clamps provided (see mounting drawing).
2. Connect the motor cable and power cable to the 11-way connector provided as per the wiring diagram. (Note: The NM range and Type C wipers have the Motor cable pre-wired).
3. Connect the Park Switch cable to the 3-way plug in connectors provided as per the wiring diagram.
4. Connect any required Heat/Wash/Purge cabling to the 11 way or 9-way connector if present.
5. The bus consists of a four wire connection. Wiring is recommended to consist of a twisted pair for the communication lines (+, -) and a twisted pair for the power lines (24V, 0V) of a minimum 0.5mm cross-sectional area (not supplied). The cable must comply with the DeviceNet specification and the communication pair have a characteristic impedance of 120 Ohms.
6. The RS 485 bus must be wired as one continuous bus without splitting of the wiring. The keypad is a master controller so must be at one end of the bus.
7. A terminating resistor module must be connected across the BUS+ and BUS- connections on the last module in the chain.

### Technical specifications modules.

Input supply motor PCB	115 or 230 Vac 1Ph
Input supply additional PCB	24Vdc, 115Vac or 230Vac 1Ph
Wash output	min 40mA, max 6A
Purge output	min 40mA, max 6A
Case heat output	min 40mA, max 6A
Window heat output	min 40mA, max 6A

# 11.7 6100 Module wiring.

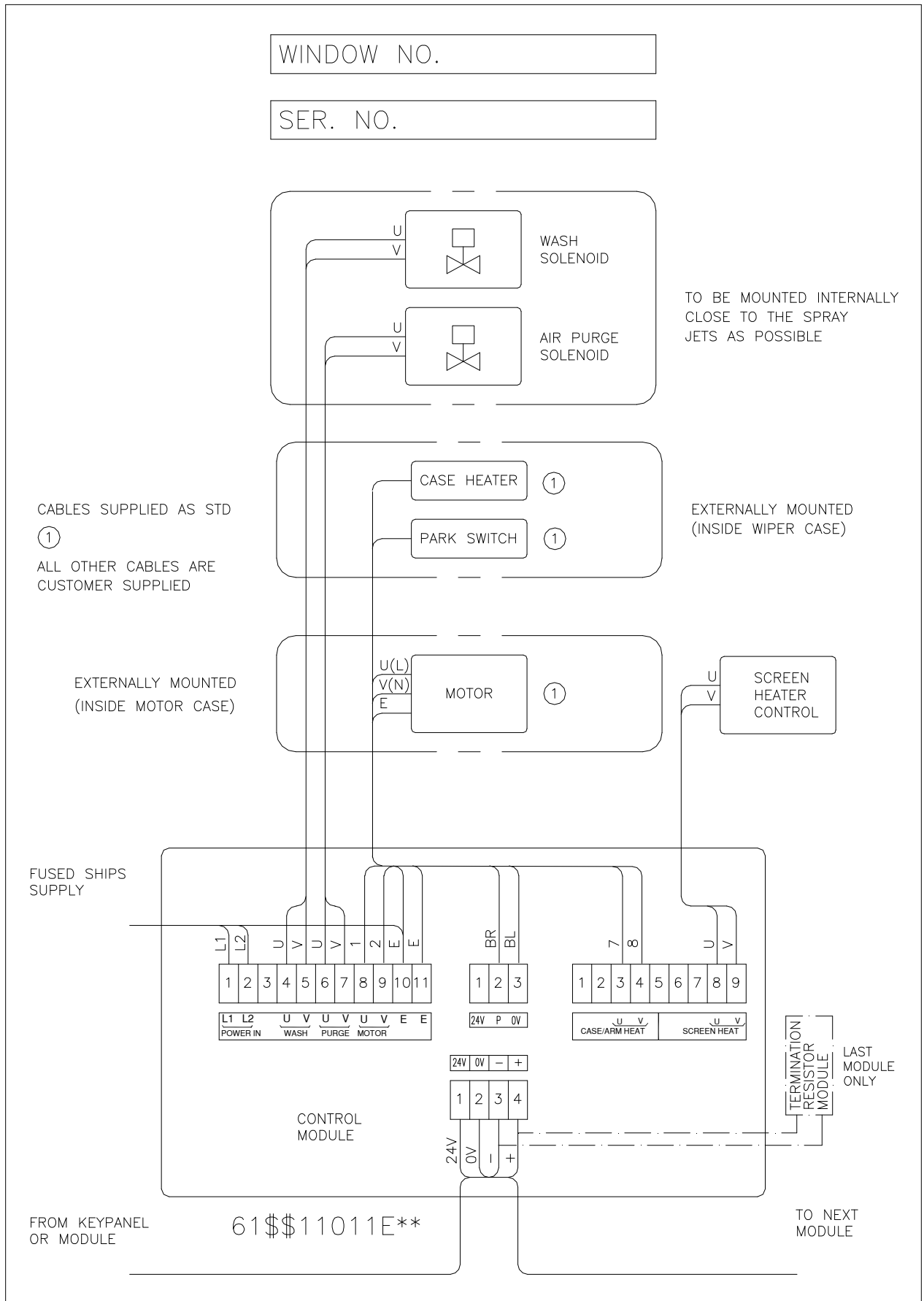

## 11.8 6300 Module Installation.

Wiper modules must be mounted within the same group, the group number being marked on the control module labelling and illustrated on Bridge Layout drawings.

For 6300 modules, motor power only is provided on the 11-way connector. Heat and Wash may be controlled via the additional 9-way connector if fitted.

Recommended is to use one output per module for case heater output, this saves cable cost.

For split power sources (i.e. 230VAC Motor with 24V AC or DC Heaters), power to the Heater is derived from the 9-way connector).

1. Choose a location for the Motor Control module so that it is within range of the motor cable and park switch cable. Mount the modules with the fixing clamps provided. (See mounting drawing)
2. Connect the motor cable and power cable to the 11-way connector provided as per the wiring diagram. (Note: The NM range and Type C wipers have the Motor cable pre-wired). Power Phasing must not be swapped – if L1, L2 or L3 are incorrectly connected, internal software fusing will not function correctly.
3. Connect the Park Switch cable to the 3-way plug in connectors provided as per the wiring diagram.
4. Connect any required Heat/Wash/Purge cabling to the 9-way connector if present.
5. The bus consists of a four wire connection. Wiring is recommended to consist of a twisted pair for the communication lines (+, -) and a twisted pair for the power lines (24V, 0V) of a minimum 0.5mm cross-sectional area (not supplied). The cable must comply with the DeviceNet specification and the communication pair have a characteristic impedance of 120 Ohms.
6. The RS 485 bus must be wired as one continuous bus without splitting of the wiring. The keypad is a master controller so must be at one end of the bus.
7. A terminating resistor module must be connected across the BUS+ and BUS- connections on the last module in the chain.

### Technical specifications modules.

Input supply motor PCB	115 or 230 Vac 3Ph
Input supply additional PCB	24Vdc, 115Vac or 230Vac 3Ph
Wash output	min 40mA, max 6A
Purge output	min 40mA, max 6A
Case heat output	min 40mA, max 6A
Window heat output	min 40mA, max 6A

# 11.9 6300 Module wiring.

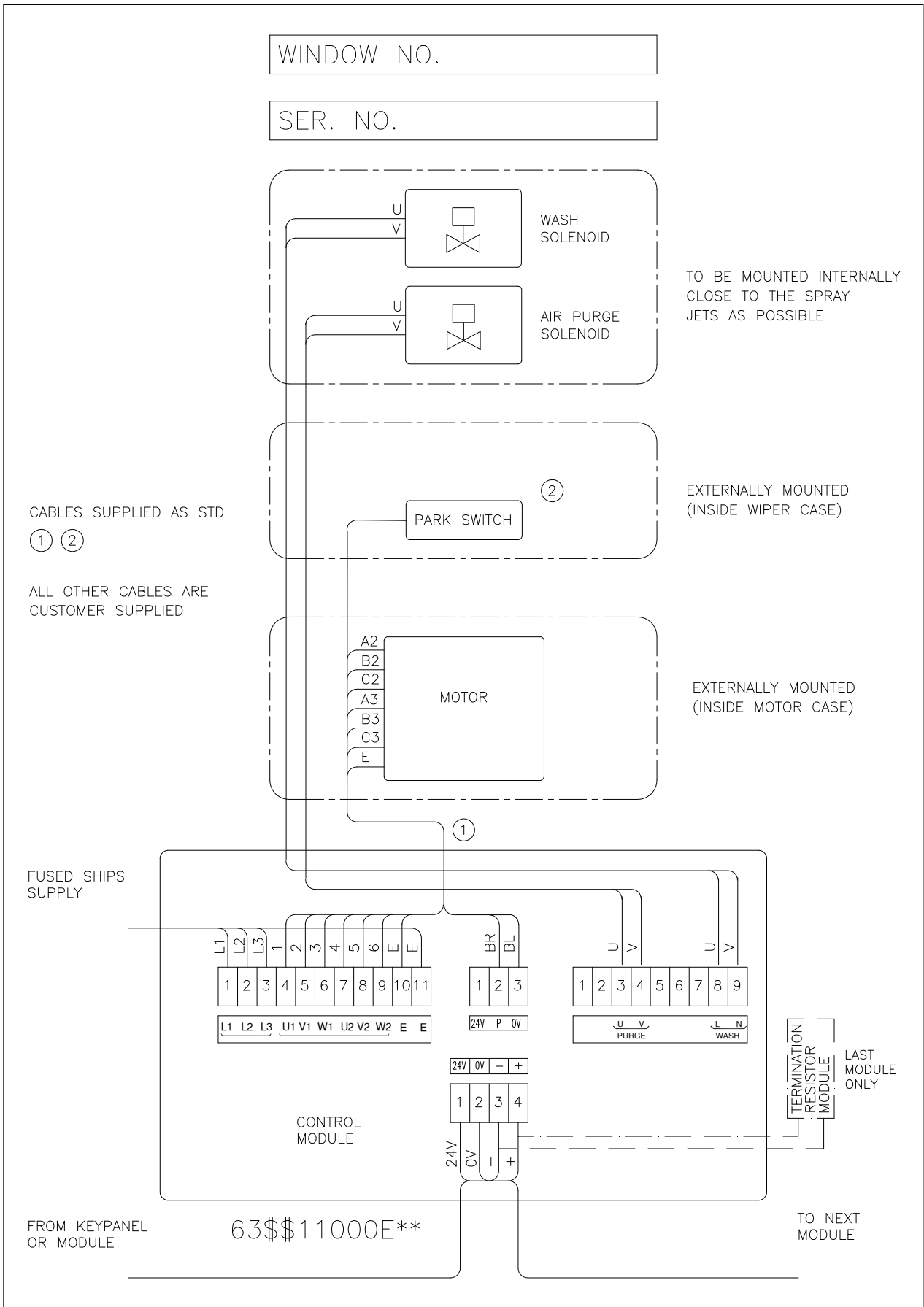

## 11.10 6100 and 6300 Module Individual Part Number (IPN).

6 Member of the 6000 series

1 or 3 Number of Phases

\*\* Motor type code The module can only be used with the motor type programmed for.

This is set to the correct current for each motor type for the current monitoring.

0 = no wash, 1 = wash AC, 2 = wash 24Vdc.

0 = no purge, 1 = purge AC, 2 = purge 24Vdc

0 = no wiper heater, 1 = window heater AC, 2 = heater DC, 3 = AC contactor drive.

E = external PSU (always).

1 to 7 Group code.

1 = 115VAC, 3 = 230VAC

## 11.11 6200 DC Module

The 6200 is a driver module for a two-speed, permanent magnet DC motor, with an additional auxiliary which can be assigned by on board DIP switches.

The auxiliary output may be used to control other functions (Wash, Air Purge, Arm Heater, Window Heater). This output may be used directly to control devices sourcing currents of up to 4.5 Amps at 24V DC, for higher currents a contactor will be required between the module and the device.

The 6200 DC Module is mounted directly to the wiper and pre-wired to the motor unless specified by the customer.

Modules may also be interconnected using the SYNC signals by simply connecting together the LoSync cables or HiSync cables (**do not connect HiSync to LoSync**). Modules that have a SYNC signal connected will be synchronised. Synchronisation may be within Groups, across Groups or a mixture of both. Wipers may be synchronised at Low speed only or both High and Low Speed. The only limitation is that modules at High speed will not be synchronised with modules at low speed.



## 11.13 6200 Module Installation.

Wiper modules must be mounted within the same group, the group number being marked on the control module labelling and illustrated on Bridge Layout drawings.

The 6200 DC Module is mounted directly to the wiper and pre-wired to the motor unless specified by the customer.

1. Connect the motor cable to the motor.
2. Connect the motor DC power input to the Brown (+24V DC) and White (0V) (some units may have a Blue core instead of white).
3. Connect the auxiliary output (if required) to the Black (+24V) and Yellow/Green (0V).
4. Connect the bus power to the Orange (+24V) & White/Orange (0V).
5. Connect the bus signal to Blue (Bus+) & White/Blue (Bus-).
6. If required, connect the Green wires of each module together for low speed synchronisation.
7. If required, connect the White/Green wires of each module together for high speed synchronisation.
8. The RS 485 bus must be wired as one continuous bus without splitting of the wiring. The keypad is a master controller so must be at one end of the bus.
9. A terminating resistor module must be connected across the BUS+ and BUS- connections on the last module in the chain.

### Technical specifications 6200 modules.

Input supply 6200 24Vdc, +/- 10% (21.6Vdc – 26.4Vdc)  
Auxiliary output min 40mA, max 5A

## 11.14 6200 Module Individual Part Number (IPN).

*6200 member of the 6000 series.  
0 = none, W = wash, H = heat, P = purge  
1 to 7 Group code.*

# 11.15 6200 Module wiring.

24 VDC MOTOR

AUX HTR O/P

WINDOW NO.

SER. NO.

CABLES SUPPLIED AS STD

① ②

ALL OTHER CABLES ARE CUSTOMER SUPPLIED

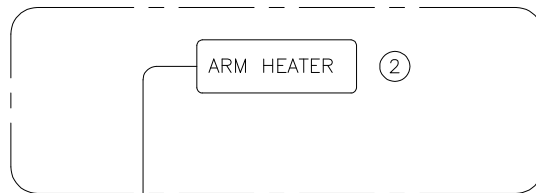

EXTERNALLY MOUNTED  
(INSIDE WIPER ARM)



INTERNALLY MOUNTED

THE UNITS ARE PREWIRED AND CLAMPED TO THE SIDE OF THE MOTOR.

AUXILIARY CABLE COLOURS:-

BROWN +V SUPPLY  
 BLUE 0V SUPPLY  
 BLACK +V AUX OUT  
 GRN/YEL 0V AUX OUT

BUS CABLE COLOURS:-

BLUE BUS +  
 WHT/BLU BUS -  
 ORANGE +24V BUS POWER  
 WHT/OR 0V BUS POWER  
 GREEN LoSync  
 WHT/GR HiSync

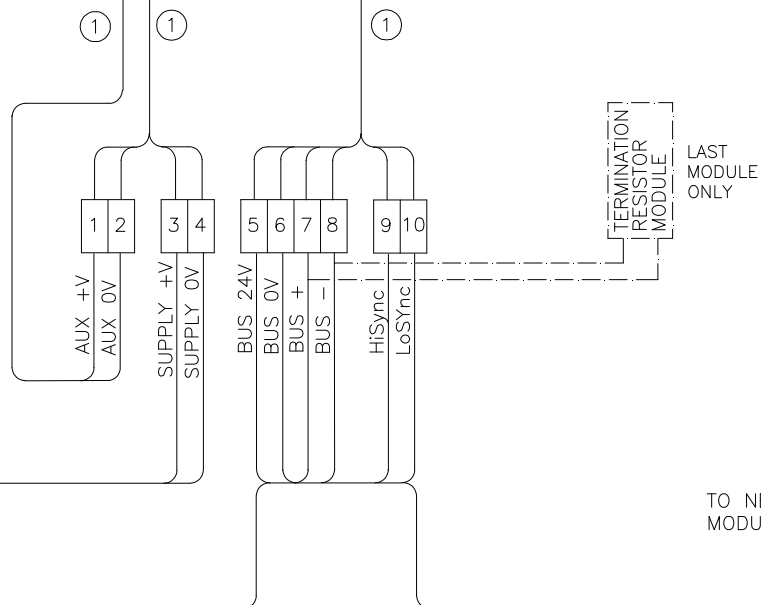

FUSED SHIPS SUPPLY

FROM KEYPAD OR MODULE

TO NEXT MODULE

## 12.0 External PSU.

The control system is 24Vdc +/- 5%. Even in 24 Vdc power supply systems we recommend to use a PSU to ensure a clean supply.

We offer the PSU 3000-006.

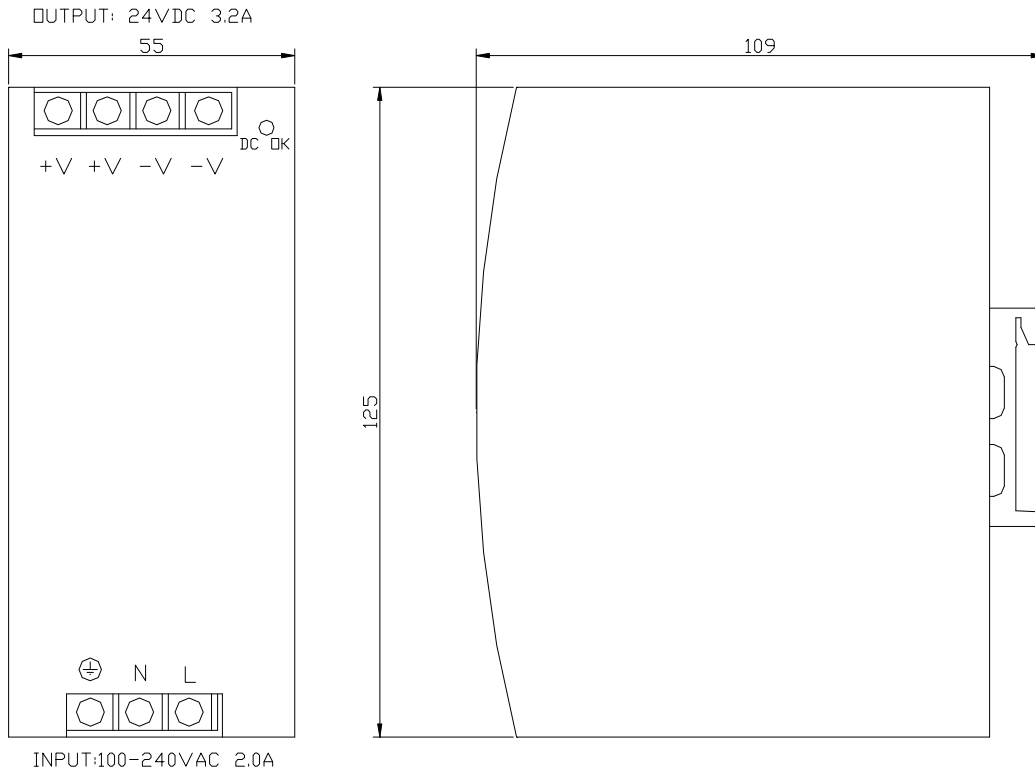

B-Hepworth Group, Hepworth Marine, 2-4 Merse Road, North Moons Moat, Redditch,  
Worcestershire B98 9HL

Tel: +44(0)1527 61243, Fax: +44(0)1527 66836, Website: [www.b-hepworth.com](http://www.b-hepworth.com)